

EZ ELECTRIC POWER STEERING

INSTALLATION MANUAL

BMW E21

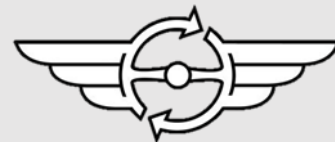



CONTENTS

THE PRODUCT.....	1
OVERVIEW OF THE KIT.....	2
INSTALLATION	7

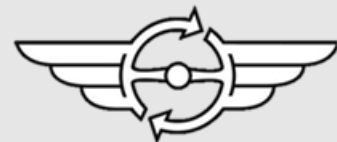

THE PRODUCT

Thank you for choosing an EZ ELECTRIC POWER STEERING product for its quality, it's performance, type approval and its straightforward assembly. Since 2006 we have been manufacturing complete steering columns with integrated electrical assistance. All columns are tailor made for each type of car and we have over 200 different types in stock. For more information about our products (power steering systems and replica steering wheels) or to place an order, visit our website www.ezpowersteering.com or send an e-mail to info@ezpowersteering.nl. If you have any questions of a technical nature please contact workshop@ezpowersteering.nl.

Version C1.1

Date 15-04-2026

This manual should be read carefully to avoid errors. Check whether all parts of the set are present. This can be done on the basis of the picture in this manual.

Before installation, compare the EZ POWER STEERING column with the original column. Check that the dimensions are the same. Also fit the steering wheel to the column.

If you do not have the skills or tools to perform the installation, have it performed by a professional. EZ POWER STEERING cannot be held liable for incorrect installation or self-inflicted damage.

The manuals are generally based on a left-hand-drive vehicle. In most cases, the right-hand drive version is the mirror image of the installation of a left-hand drive vehicle.

If you think that any changes are needed in this manual, we would like to receive your pictures and comments. With your feedback we can improve our manuals!

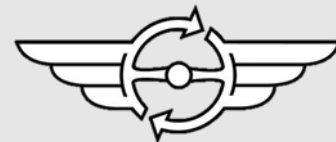

OVERVIEW OF THE KIT

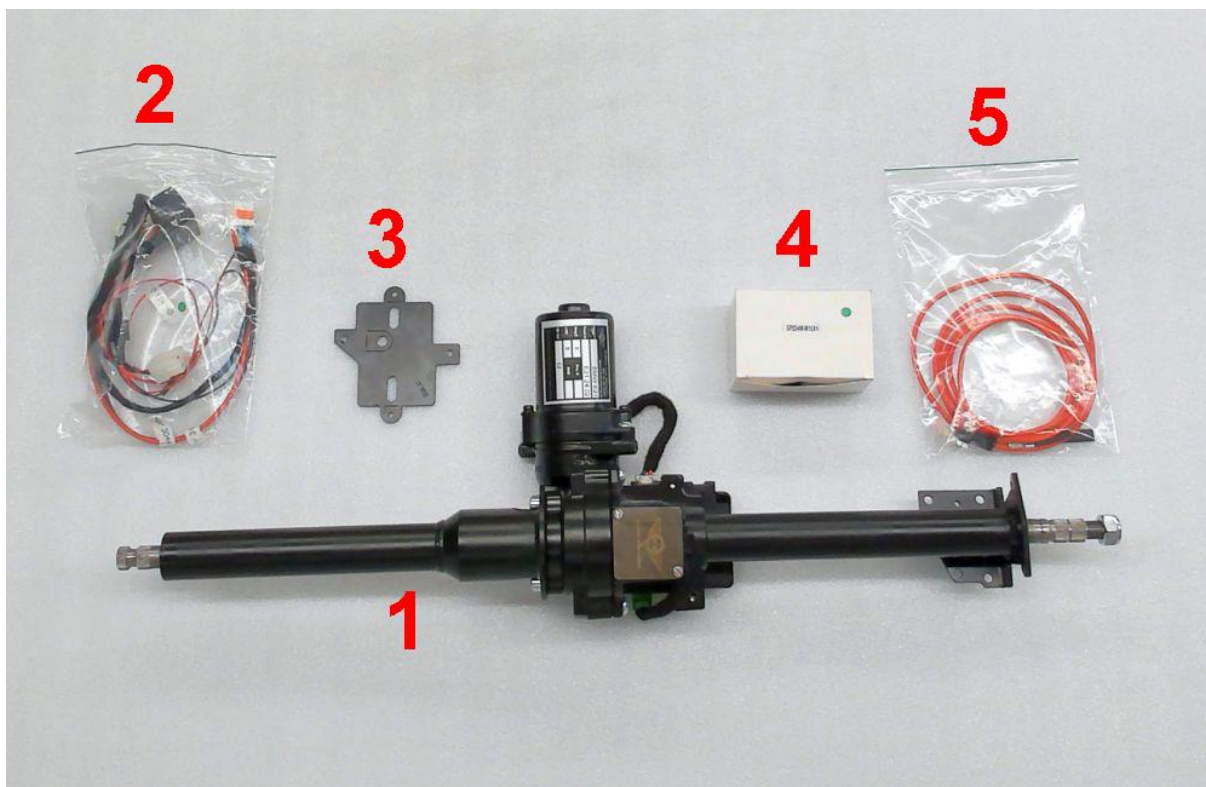

- 03.B.014 – 1 – EZ set
- 03.B.014 – 2 – Wiring harness + controller
- 03.B.014 – 3 – Additional mounting plate for ECU (optional)
- 03.B.014 – 4 – Speed sensor
- 03.B.014 – 5 – Power supply cable

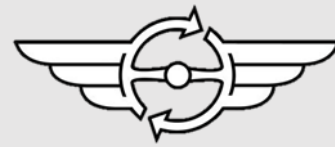

GENERAL INFORMATION

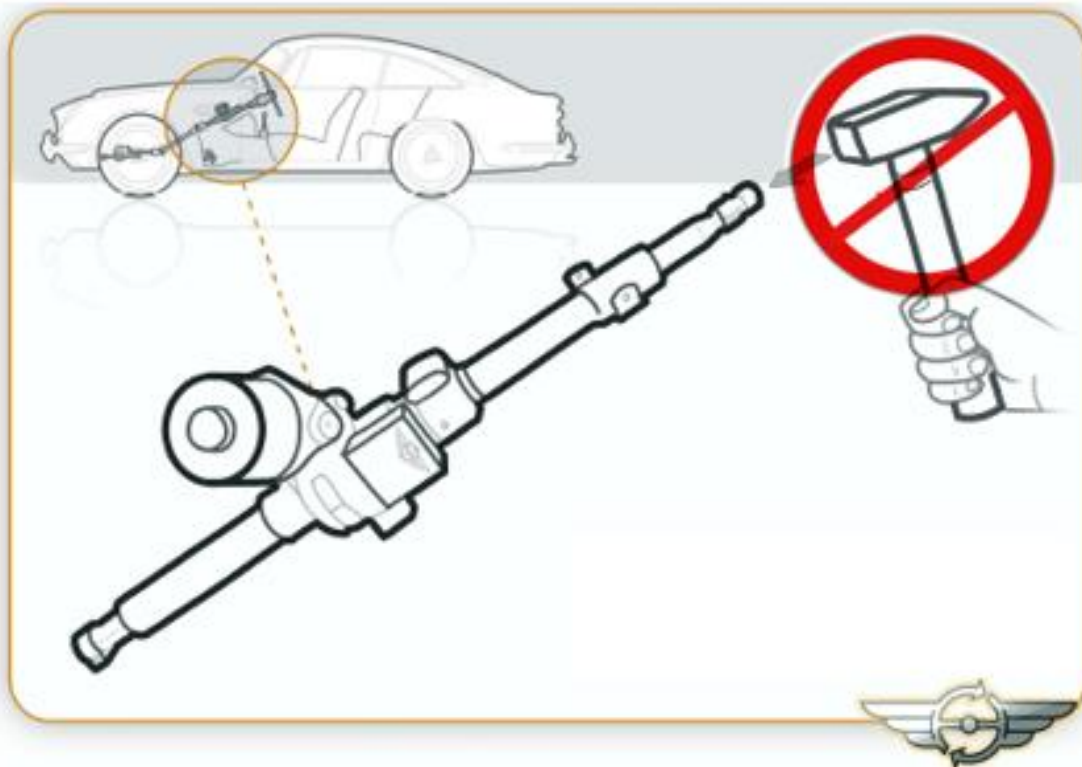

Never hit the input shaft with an object during or after installation. This can negatively affect the sensors.

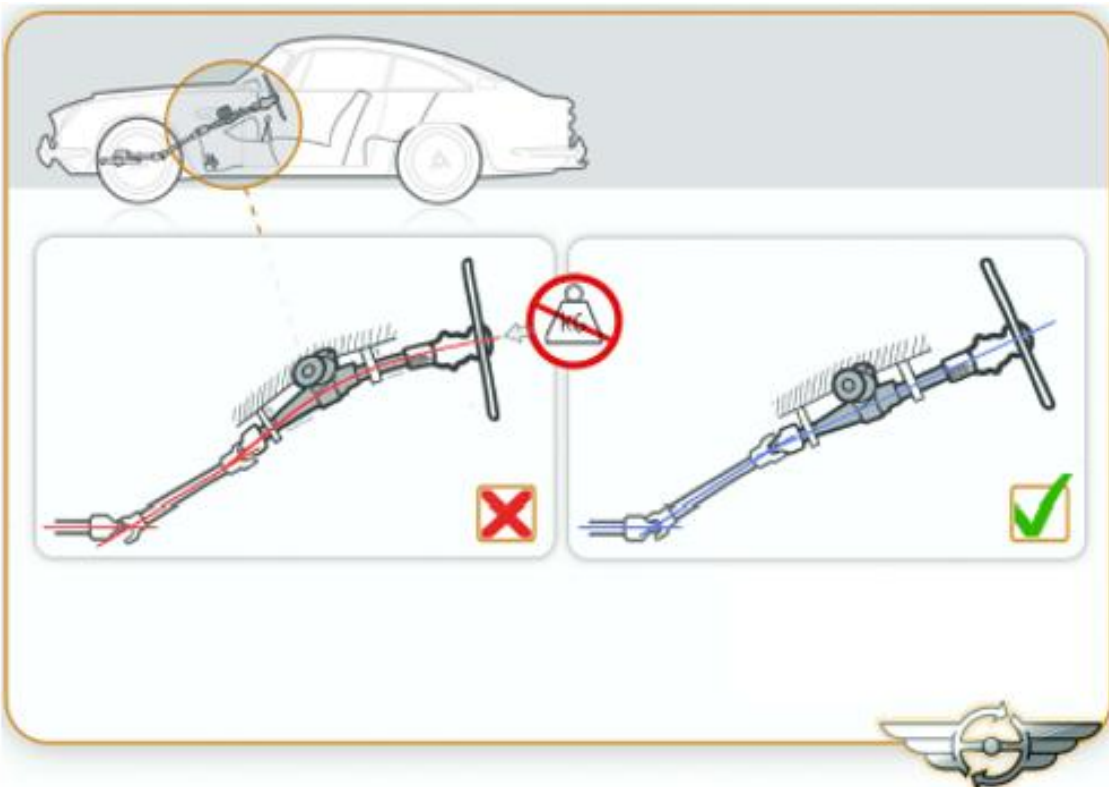

The steering system must always be fitted tension free and properly aligned.

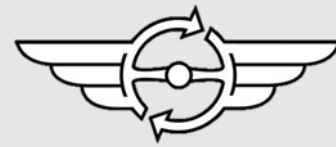

Check length, diameter and splines

Compare the EZ Power Steering Column (EZ-unit) with the original steering column before installing it. The total length of the EZ unit may differ slightly from that of the original steering column to make installation easier. Check if the splines on the top and bottom, the diameter of the steering tube and the length of the column are all the same as the original steering column. When in doubt you can use the original steering wheel to check the top splines for fit. Never hammer on the steering shaft of the EZ unit!

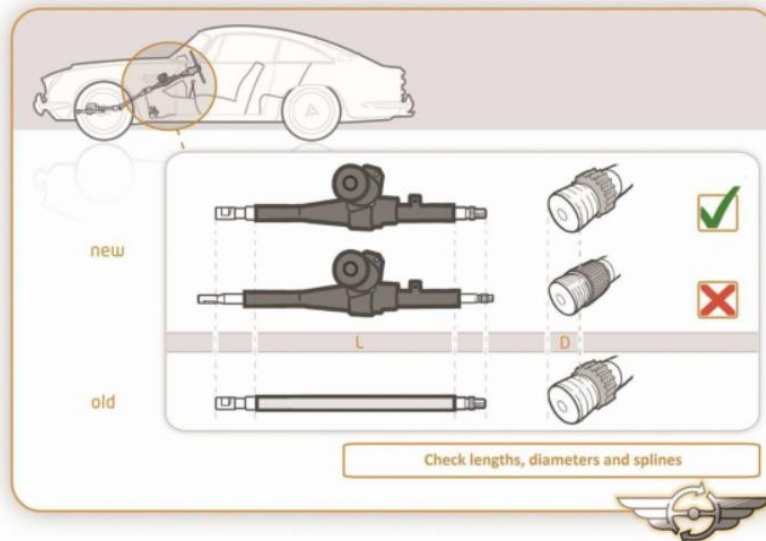

In the car industry it's common to have some small tolerances in spline connections. In very exceptional cases connecting a new shaft from the EZ-unit in the original (old) U-joint could cause a tight fitting. This is sometimes relatively easy to solve by sanding only about 0,2mm (0,007 inch) in the inner part of the U-joint and also the spline on the output shaft on the EZ-unit.



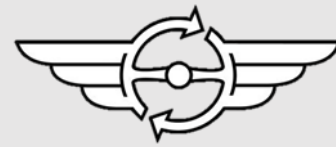

Torque tightening values in Nm.

When the new steering column is being fitted hand tighten all the bolts and check if everything turns smoothly before tightening to required Torque, use torque tightening table below:

	strength class 8.8	strength class 10.9	strength class 12.9
Bolt M6	11	16	19
Bolt M8	27	40	47

The system works with a torsion bar into the unit, this measures the amount of torque/load on the steering shaft while steering, the torque sensor measures this and sends a voltage to the ECU. The ECU uses this signal together with the speed signal to control the electric motor from the EZ-unit.

Voltage

The basic EZ-unit, is a 12V system with negative earth! There are extra wiring sets available, so that the kit will work with a 6V or 24V system and/or positive earth. Check your vehicle setup before fitting the EZ-unit.

The red supply wire (30+) has to be connected directly to the starter relay or the plus terminal of the battery and fused with the supplied 40 Ampere fuse.

Connect the black ground wire (31-) cable eyelet to a suitable earth point (not to the column). If you have a positive earth car (Plus battery terminal connected to the chassis) ensure that you have the correct wiring loom with additional relay

The thin red wire is ignition switched (15+) and should be connected to a fused contact switched power supply. Check the voltage between the ignition switched plus against earth, with switched on ignition, this must be at least 11,5 Volt. If it drops below this the electric power steering will switch off. (When this happens during driving, the vehicle will drive similar as before the EZ conversion).

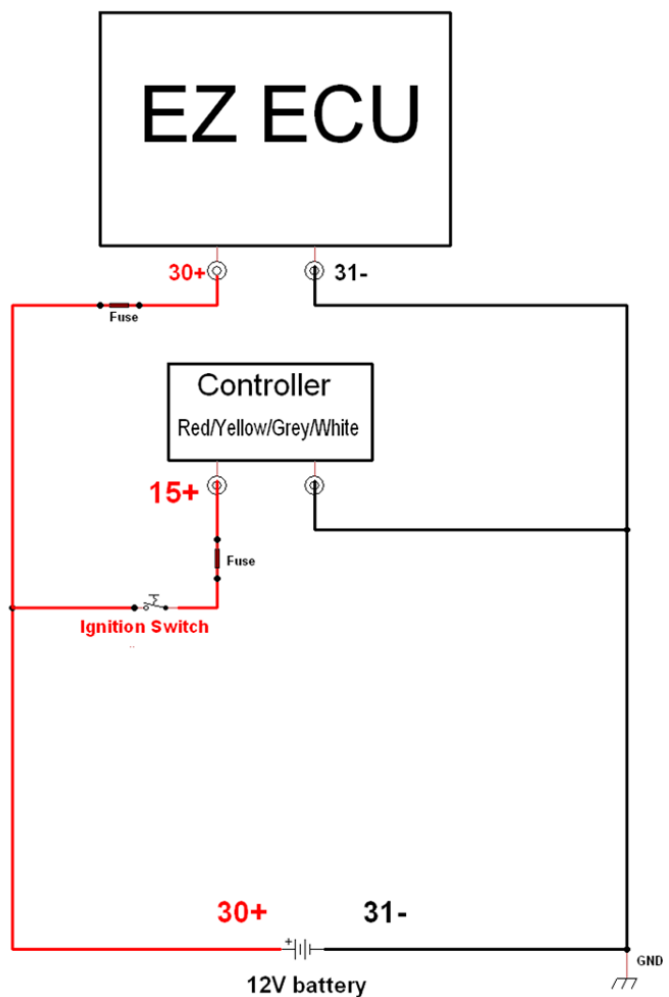

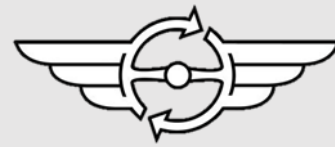

Be sure to measure the voltage under load (with other electrical devices switched on like: cooling fan, windshield wiper or electric window defroster, etc.) and with running engine.

If needed there are electronic devices available, to maintain the correct ignition switched voltage above 11.5V!

Also a simple test of the electronics is to check if you hear a click after switching on the ignition, another click should be heard after 1 or 2 seconds after switching off the ignition

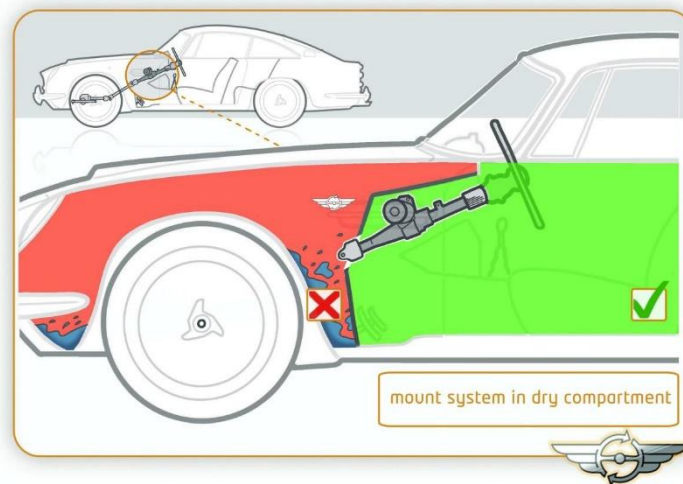

The EZ unit, wiring loom, ECU and other electric components may not be exposed to high temperatures (60 degrees centigrade or higher) or a wet environment.

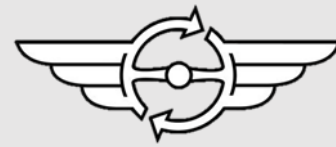

INSTALLATION

Step 1.

Inspect the tyre pressure and test drive the car. Check that the steering wheel self-centers. Exeman that the steering and instruments are not defective. If everything this is in order, proceed with the conversion.

Step 2.

Find a fused power supply switched via the ignition. This is necessary for the power supply of the EZ powersteering unit (see step 15). The switched power supply can either be taken from the ignition switch or from the fuse box. Then disconnect the battery negative terminal lead and put the front wheels in the straight-ahead position.



Step 3.

Remove the steering wheel from the car.

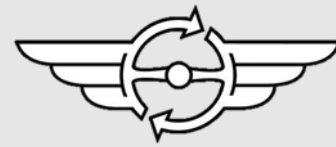

Step 4.

Remove the plate under the dashboard, this gives access to the steering column.



Step 5.

Disconnect the control switches, the contact and horn plug.

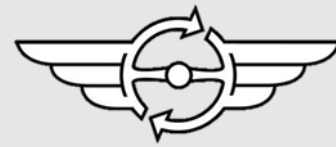

Step 6.

Loosen the upper bolt of the universal joint in the engine compartment.



Step 7.

Loosen the locking bolts of the steering position by means of a left tap or a hammer and chisel.

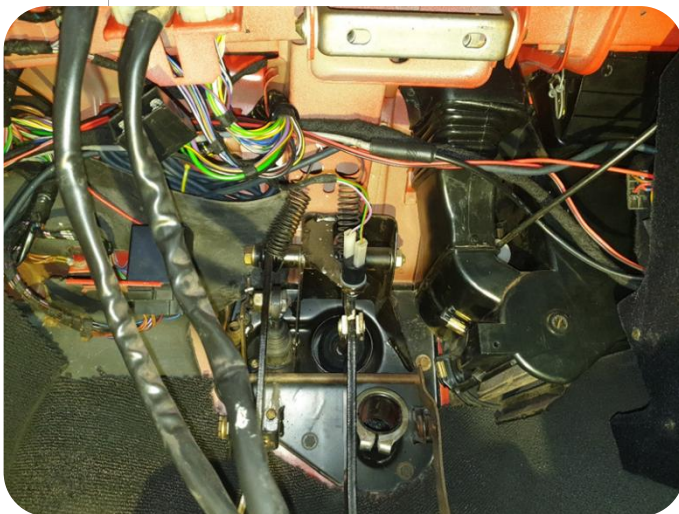

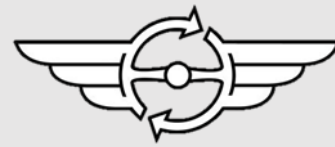

Step 8A.

From the original column you only need to transfer the bushing to the EZ column.

Then go to step 10



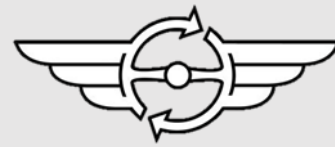

Step 8B.

In some cases it is necessary to use part of the original column.

If the top of the column is not included:

Measure the projection distance of the steering axle relative to the steering tube of the disassembled steering column and record this dimension. Now remove the steering axle from the steering tube. Saw off the original steerer tube to the end of the aluminum cap. The sawn-off part of the column will soon make way for the EZ column.



Step 9.

Cut the original tube of the column in on two sides, as shown in the photo.

When everything is put back together again check the previously noted overhang.

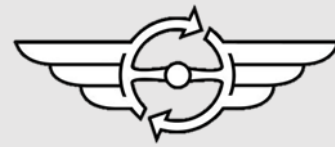

Step 10.

You can slide the metal cover partially under the ECU.



Step 11.

Remove a small section of the lower plastic cover to make room for the torque sensor.



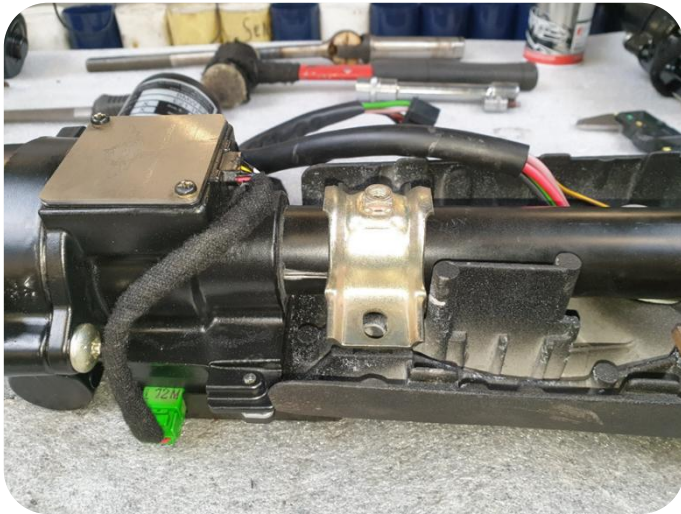
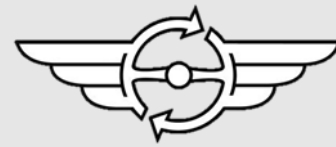

Step 12.

Then adjust the clamp over the original column. Also prepare the wiring in the car.

Step 13.

Connect the thick red wire (30+) from the fuse holder directly to the positive battery. It is advisable to extra isolate the wire.

Step 14.

Connect the black wire (31-) to a suitable clean ground point and connect the EZ cable harness.

Step 15.

Connect the thin red wire (15+) to a fused ignition contact switched power supply (see point 2)

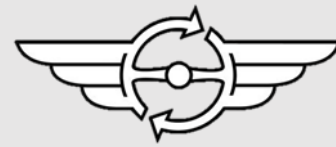

Step 16.

If the car is fitted with a speed sensor, this is the easiest thing to do as long as the steering column is not in it.



Step 17.

Now put the column back in the car, make sure it is pushed against the universal joint and then put the column on the dashboard in the bracket. (sometimes it may be easier to remove the ECU first).



Step 18.

Tighten the clamp on the bulkhead.

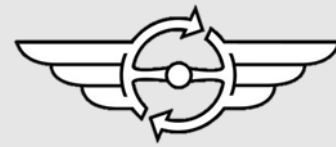

Step 19.

Tighten the universal joint.

Step 20.

Check if the wiring is connected and then re-install the control switches.

Check all the confirmation points of the column once more.

Step 21.

Reinstall all covers.

Step 22.

Refit the steering wheel

Step 23.

Connect the previously disconnected battery negative terminal lead. After switching on the ignition a click can be heard from the ECU, the system is now operational, check this by making steering movements. After switching off the ignition a click is heard again after about 3 seconds. The system is now switched off.

Step 24.

Take a test drive and check all systems again. Also check if the position of the steering wheel is correct, if not adjust it.